

MICRO GROW

GREENHOUSE SYSTEMS, INC

26111 YNEZ RD., SUITE C-4, TEMECULA, CA 92591 PHONE (951)-296-3340 FAX (951)-296-3350

Revision 1.3, 8/30/04

Ventmate Plus

INSTALLATION PROCEDURES

GROWMASTER, GROWMATE PLUS, AND VENTMATE PLUS

PANEL MOUNTING

Mount the control panel in an accessible location. Make sure that the location is free of vibration and in close proximity to the devices being controlled. Always consider voltage drop of electrical current when locating the control panel. Securely mount the panel.

SWITCHING CONTACTORS AND RELAYS

The control panel will operate the greenhouse equipment by way of load contactors and load relays. **ALL RELAYS AND LOAD CONTACTORS USED MUST HAVE A SURGE SUPPRESSOR INSTALLED ACROSS THE COIL OF THE RELAY OR LOAD CONTACTOR.** These surge suppressors are readily available from Micro Grow Greenhouse Systems, Inc. All load contactors and relays are also readily available from Micro Grow Greenhouse Systems, Inc. To decide which to use, follow this guide:

LOAD CONTACTORS:

Exhaust fans, pad pumps, horizontal air flow fans, heating pumps, fan jets, large heaters, crop lighting, and all other larger electrical loads over 1/6 H.P.

LOAD RELAYS:

Signal switching such as the small control lines for gas fired heaters, control lines for vent and shade system controls, small loads such as motorized shutters, other loads up to 1/6 H.P.

CUSTOM CONTACTOR AND RELAY PANEL AVAILABLE

A custom-built load contactor and load relay panel is available from Micro Grow Greenhouse Systems, Inc. This panel will contain all the required switching apparatus for your project, as well as a correctly sized machine tool transformer. Contact Micro Grow Greenhouse Systems, Inc. for pricing and availability.

TRANSFORMERS

A 24 VAC transformer will power the control panel. It is most important to use a MACHINE TOOL TYPE. A Machine Tool Transformer is a heavy-duty variety that will allow for high inrush currents that are associated with the use of load contactors and relays. Micro Grow Greenhouse Systems, Inc. stocks these types of transformers. Use no smaller than a 50 VA Machine Tool Transformer. For a system that has more than three load contactors connected, use a 100 VA Machine Tool Transformer.

ELECTRICAL CIRCUITS

The electrical circuit that feeds the machine tool transformer must have no other loads connected to it. This will prevent damaging surges from other related electrical devices. Follow all local and national codes in the connection of all the greenhouse equipment. Always allow for voltage drop conditions. Always consider that the greenhouse is a wet environment. Always follow the code rulings for disconnect switches and overcurrent devices on greenhouse equipment. **USE A QUALIFIED AND LICENSED ELECTRICIAN AT ALL TIMES.**

WIRING METHODS

Always use stranded wire when connecting cables or conductors to the actual circuit board of the control panel. This will allow flexibility. Use no smaller than #18 gauge-stranded wire for all

outputs. Use no smaller than the recommended wire size of stranded cable for inputs, generally #22 gauge.

SENSOR CONDUCTORS:

Route sensor conductors separately from control conductors. This is very important so as to reduce electrical interference. Never route sensor conductors in conduits used for other voltages. This is in violation of the electrical code and will cause dangerous interference to the control system. Always locate the actual sensor in the center of the range that is being controlled for accurate readings. Do not allow the sensor to come in contact with any greenhouse structure member such as a post that would give off any radiated heat and cause a false temperature reading. Do not locate the sensor where a particular piece of equipment would cause false readings, such as a heater blowing directly on the sensor. If using a weather station, mount the wind/rain sensor in a clear area, free of any wind obstructions.

CONTROL CONDUCTORS:

Route all control conductors separately from sensor conductors. This is very important so as to reduce electrical interference. Control conductors maybe routed in conduits that contain other power system wiring only if the insulation material on the conductors is the same as the power system wiring. Consult the national electrical code or local codes if in doubt about the insulation ratings of the wire in use. Remember; always use a qualified and licensed electrician.

VENT SYSTEMS, SHADE SYSTEMS, ROLL UP CURTAINS

When connecting a vent system, shade system, or roll up curtain ventilation system to the control panel, you must use a separate control box designed for that particular vent or shade system. These are readily available from Micro Grow Greenhouse Systems, Inc. Generally these separate control boxes feature overcurrent protection for the particular motor on the vent or shade system, provisions for direct limit switch connections, and a manual means of operating the vent or shade system independent of the main control system. These separate control boxes will connect the main control system either directly through the outputs of the control system, or they will require control relays for interconnection to the main control system. Consult the individual instructions that come with the vent or shade controls for detailed information.

SYSTEM TESTING

It is always important to completely and fully test the electrical system by energizing circuits and verifying equipment operations before automatically operating the equipment from the control panel. This would include setting all the vent and shade limit switches at the individual control panels.

PROGRAMMING SWITCHES

There are two main programming switches located on the Ventmate Plus front panel. These are:

RUN-SET SWITCH

RUN - Returns the control to the run mode.

SET-Advances through the program lights to program the system.

VALUE SWITCH

UP-Increases the value of the displayed item.

DOWN-Decreases the value of the displayed item.

PROGRAMMING LIGHTS

The programming lights or LED's indicate the mode that the system is in when programming or operating.

RUN - System is in the running mode.

VENT A-This will light when set Vent A temperatures.

VENT B-This will light when set Vent B temperatures.

HEATING - This will light when setting heating temperatures.

SET MODE/CLOCK- This will light when setting up the day, night and DIF modes and the internal time clock.

CALIBRATE - This will light when the system is in calibration mode.

SET UP VENT - This will light when setting the vent timing, and time delays.

TO PROGRAM VENT AND HEATING TEMPERATURES

DAY TEMPERATURE SETPOINTS:

1. Toggle the **SET** switch down until the **VENT A** LED light is on by itself and the **DAY MODE** indicator on the LCD display is flashing, release the switch.

2. Hold the **VALUE** switch either **UP** or **DOWN** until the desired temperature is displayed, release switch.

The Vent A temperatures for the day mode are now set. For Vent B, perform the above but substitute "Vent B" for "Vent A". For heating:

1. Toggle the **SET** switch down until the **HEATING** LED light is on by itself and the **DAY MODE** indicator on the LCD display is flashing, release the switch.

2. Hold the **VALUE** switch either **UP** or **DOWN** until the desired value is reached, release switch.

YOU CANNOT PROGRAM THE HEATING TEMPERATURES HIGHER THAN THE VENTILATION` TEMPERATURES.

NIGHT TEMPERATURE SETPOINTS:

1. Continue to toggle the **SET** switch down until the **NIGHT MODE** indicator on the LCD display is flashing on the LCD display along with either the **VENT A**, **VENT B** or the **HEATING** light, release the switch.
2. Hold the **VALUE** switch either **UP** or **DOWN** until the desired NIGHT value is displayed, release switch.

TO SET THE DAY, NIGHT, AND DIF MODE TIMES

The control can detect night automatically with the use of an external photocell. If no photocell is connected, it will use the internal 24-hour time clock. You can also use a combination of both if desired.

1. Continue to depress the **SET** switch until the **SET MODE/CLOCK** LED is on and the **DAY MODE** indicator on the LCD display is on. The word "**PHO**" will be displayed. This indicates that the control will use the photocell to go into the day mode. If the internal time clock preferable, use the value switch to advance to a time of day setting. The first value will be hours. Depress the **SET** switch again to set the minutes, and again to set AM or PM.
2. Depress the **SET** switch again so that the **SET MODE/CLOCK** LED is on and the **NIGHT MODE** indicator on the LCD display is on. Repeat the same procedure as in the above **DAY MODE** setting for the desired NIGHT MODE selection.
3. Depress the **SET** switch again so that the **SET MODE/CLOCK** LED is on and the **DIF MODE** indicator on the LCD display is on. If DIF is not to be activated, adjust the flashing value to "**OFF**". If DIF is to be activated, adjust the flashing value, "**bEF.X.X**", to indicate the number of hours before sunrise to go into DIF. Depress the **SET** switch again and adjust the flashing value, "**AF.X.X**", to indicate the number of hours after sunrise to come out of DIF.

To Set the Clock:

1. Toggle the **SET** switch until the **SET MODE/CLOCK** LED is on and the Ventmate Plus is showing the current time. The item to be set will be flashing. Use the **VALUE** switch to raise or lower the flashing value. The first value will be hours. Depress the **SET** switch again to set the minutes, and again to set if it is AM or PM.
2. Return to the **RUN** mode by toggling the **RUN-SET** switch up.

To Set Vent Information

TO SET THE NUMBER OF STAGES:

Toggle the **SET** switch until the **SET UP VENT** and **VENT A** LED is on. The number of stages for Vent A will be flashing. Use the **VALUE** switch to raise or lower the flashing value. The Ventmate Plus will automatically divide the percentage open for each stage. For example, a 4-position selection will allow each stage to open 25%.

TO SET THE OPENING TIME:

Toggle the **SET** switch until the **SET UP VENT** and **VENT A** LED is on and the LCD display is showing "**OP XXX**", where the "**XXX**" is the time in seconds that the vent will take to go from a fully closed to a fully open position. Use the **VALUE** switch to raise or lower the flashing value.

TO SET OVERRIDE POSITION:

Toggle the **SET** switch until the **SET UP VENT** and **VENT A** LED is on and the LCD display is showing "**Or: XX**", where the "**XX**" is the position that the vent will go to on an override signal

input. Use the **VALUE** switch to raise or lower the flashing value. If an override is not being used, ignore this step.

TO SET SAFETY DELAY:

A safety delay is the amount of time that your particular vent motor waits to operate upon being sent a signal. This delay is always built into the vent control cabinet. Consult your ventilation motor and controller supplier if you are not sure if you have a safety delay or not.

Toggle the **SET** switch until the **SET UP VENT** and **VENT A** LED is on and the LCD display is showing "**SAF X**", where the "**X**" is the delay in seconds to protect the vents against false reversals. If the vent starts to move immediately, after manually energizing it, there is most likely no time delay protection. Use the **VALUE** switch to raise or lower the flashing value. You may choose "**0**" as one of the choices.

TO SET THE TIME DELAY:

The time delay is the amount of time that the Ventmate Plus will wait before opening or closing the vent or turning on or off the heating stages.

Toggle the **SET** switch until the **SET UP VENT** and **VENT A** LED is on and the LCD display is showing "**dLY X**", where the "**X**" is the delay in seconds on both energizing and de-energizing stages. Use the **VALUE** switch to raise or lower the flashing value.

RUN MODE

After all settings have been made, return to the **RUN** mode by toggling the **SET** switch down until the **RUN** LED light is on, release switch. The control will return to the **RUN** mode by itself when no other switches are depressed after a timed delay.

HIGH and LOW HISTORY

The control will automatically track the high and low readings for the past 24 hours for both inputs. The control will automatically display the high and low reading for the temperature.

TO CALIBRATE THE CONTROL

To calibrate the control system, follow these instructions:

1. Determine the actual temperature at the sensor location. It is best to do this either in the evening or early morning. The solar effect of the greenhouse will provide an inaccurate temperature reading. Always use a good calibration thermometer, digital or mercury, and allow the temperature to stabilize before proceeding. Make sure that all greenhouse heating or cooling equipment has been off, or has not changed operation status for several minutes before calibration. This will help to insure accurate readings.
2. At the control panel, toggle the **SET** switch till the **CALIBRATE** LED is on. This will put the control in the calibration mode. Once the control is in the calibration mode, hold the **VALUE** switch either **UP** or **DOWN** to enter a new temperature reading in the display. Release the switch when the desired value is reached.
3. Return to the **RUN** mode by holding the **RUN-SET** switch up until the **RUN** LED light is on, release switch.

DIP SWITCH SETTINGS

The control system allows for customization of temperature separations and differentials between stage operations. These are determined by the settings of the DIP switches located on the inside of the circuit board of the control. Refer to the drawing of the actual control connections to set these DIP switches.

PHOTOCELL

The control is equipped with a photocell to detect day and night modes. The photocell is located on the bottom side of the control enclosure. Keep the photocell clean and unobstructed.

OPERATIONAL TIPS

Keep the cover securely fastened always. The enclosure is a weatherproof, gasket fitted device, but will not provide this degree of protection with the front cover open. In selecting the equipment for each stage, try to minimize energy use with the primary cooling or heating stages. This will insure a lower crop shock effect, and in turn, save on energy costs.

CONTROL CARE AND UPKEEP

Keep the front panel of control securely closed always. Prevent unauthorized personnel from changing the control settings or switches. Periodically clean the temperature sensor elements with a clean damp cloth to prevent any build-up.

THE DISPLAY WILL ALTERNATE BETWEEN THE CURRENT TEMPERATURE, AND THE HIGHEST AND LOWEST READING DURING THE LAST 24 HOURS. THE CURRENT VENT POSITION, TIME OF DAY AND MODE IS ALSO DISPLAYED.



EASY FRONT PANEL TOGGLE SWITCHES FOR PROGRAMMING AND CALIBRATION.

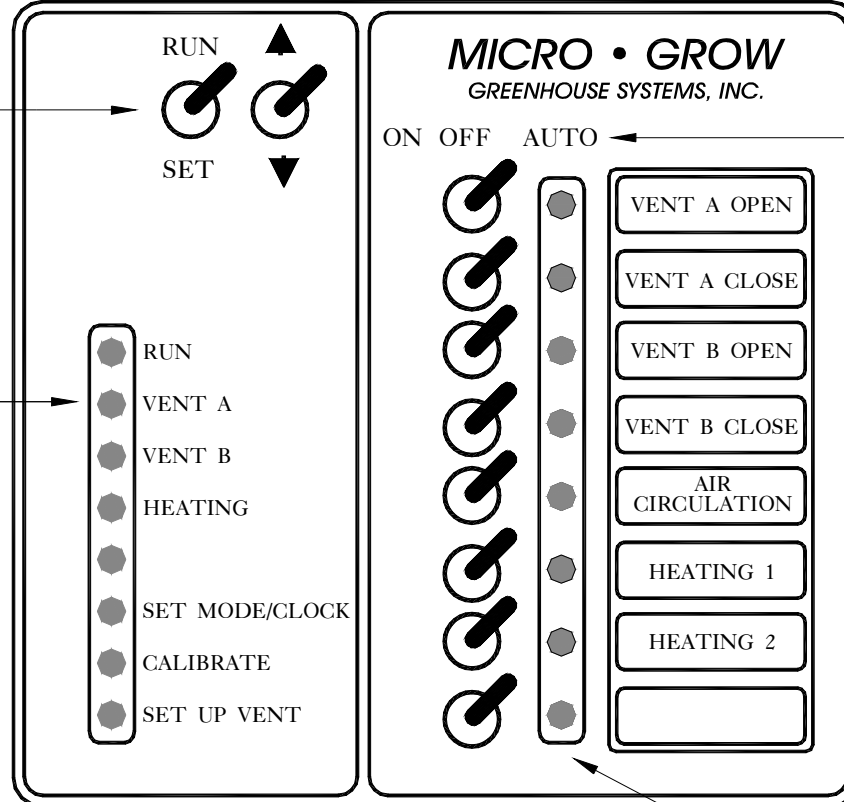

STATUS LIGHTS FOR EASY PROGRAMMING OF SEPARATE VENTILATION AND HEATING TEMPERATURES FOR DAY AND NIGHT SETTINGS, CALIBRATION AND MODE SELECTIONS ARE FEATURED.

EACH OUTPUT HAS A FRONT PANEL MOUNTED SWITCH TO SELECT THE MODE OF OPERATION. THE PARTICULAR OUTPUT MAY BE LEFT OFF, MANUALLY OPERATED, OR LEFT IN THE AUTOMATIC POSITION OF OPERATION.

LIGHTED STATUS INDICATORS WILL SHOW ANY STAGE IN OPERATION, EITHER MANUAL OR AUTOMATIC.

Project	VENTMATE PLUS FRONT PANEL	
	Order ID	N/A
Drawn by	SB	Distributor
Date	8/30/04	N/A

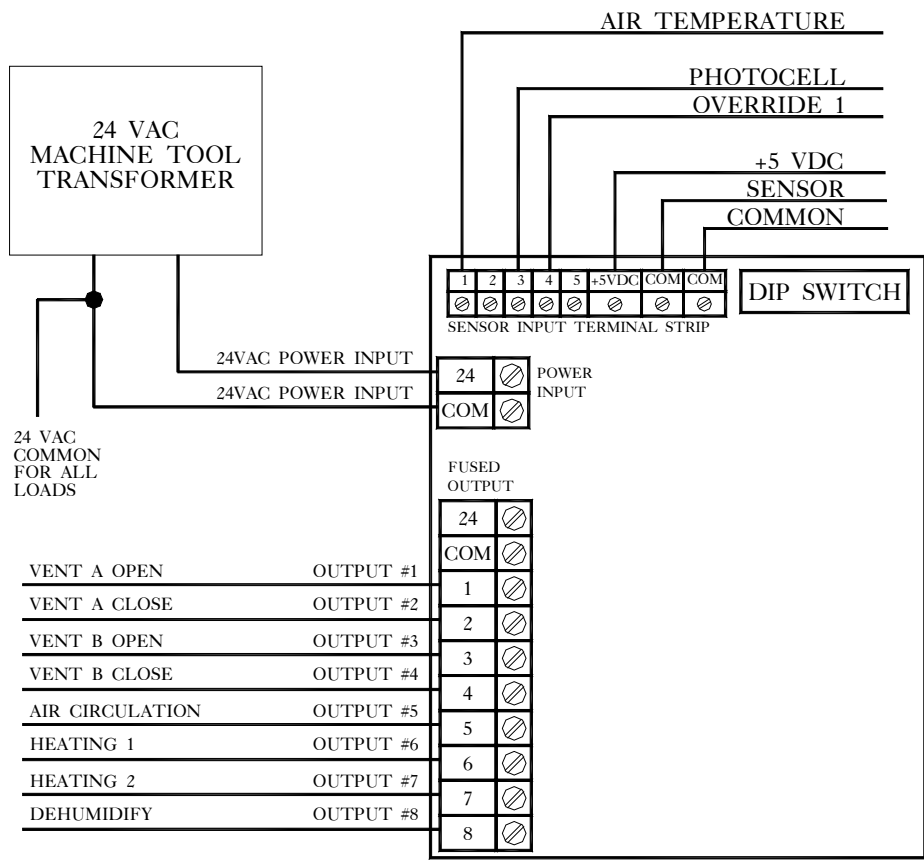

TRANSFORMER NOTE:
 USE A MACHINE TOOL VARIETY ONLY 100 VA IS RECOMMENDED. IF A SMALLER SIZED TRANSFORMER IS USED, ADJUST THE FUSE PROTECTION ACCORDINGLY. (See fuse note)

OUTPUT NOTE:
 THE CONTROL OUTPUTS ARE RATED AT 1 AMP EACH MAXIMUM. DO NOT EXCEED THIS OR DAMAGE MAY RESULT. DO NOT EXCEED 1 AMP FOR ANY SINGLE OUTPUT OR 4 AMPS TOTAL FOR ALL OUTPUTS. (2 AMPS TOTAL IF A 50 VA TRANSFORMER IS IN USE)

FUSE NOTE:
 IMPORTANT: DO NOT EXCEED 4 AMPS FOR THE FUSE RATING WHEN USING A 100 VA TRANSFORMER OR 2 AMPS WHEN USING A 50 VA TRANSFORMER. USE A SLOW BLOW VARIETY.

DIP SWITCH CONFIGURATION

HEATING SEPARATION AND DIFFERENTIAL:
 #1 OFF #2 OFF 2 DEGREES (FACTORY DEFAULT)
 #1 OFF #2 ON 3 DEGREES
 #1 ON #2 OFF 1 DEGREES
 #1 ON #2 ON 4 DEGREES

VENT SEPARATION AND DIFFERENTIAL:
 #3 OFF #4 OFF 2 DEGREES (FACTORY DEFAULT)
 #3 OFF #4 ON 3 DEGREES
 #3 ON #4 OFF 1 DEGREE
 #3 ON #4 ON 4 DEGREES

AIR CIRCULATION (NORMAL OPERATION):
 #5 OFF TURN OFF WHEN VENT A IS OPEN (FACTORY DEFAULT SETTINGS)
 #5 ON TURN OFF WHEN VENT A IS PAST STAGE 1

MAXIMUM VENT POSITION:
 #7 OFF VENT OPENS TO 100% (FACTORY DEFAULT SETTINGS)
 #7 ON VENT OPENS TO 95%

ALL CONNECTED 24 VAC LOAD RELAYS AND CONTACTORS MUST HAVE A SURGE PROTECTION DEVICE INSTALLED ACROSS THE COILS. SURGE SUPPRESSION DEVICES ARE SUPPLIED WITH EACH UNIT.
 ALL CORRECT LOAD CONTACTORS AND CONTROL RELAYS ARE AVAILABLE FROM MICRO GROW GREENHOUSE SYSTEMS. 50 AND 100 VA MACHINE TOOL TRANSFORMERS ARE AVAILABLE FROM MICRO GROW GREENHOUSE SYSTEMS. SEE YOUR DISTRIBUTOR OR CALL MICRO GROW FOR IMMEDIATE SHIPMENT OF ALL REQUIRED CONNECTION DEVICES AND ACCESSORIES.

VENTMATE PLUS

Project	
VENTMATE PLUS INPUTS & OUTPUTS	
Order ID	N/A
Distributor	N/A
Date	01/24/02
Drawn by	GH

TEMPERATURE SENSOR

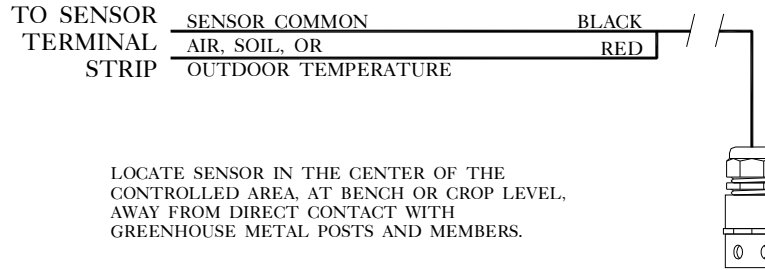

OPTIONAL ASPIRATED AIR TEMPERATURE SENSOR

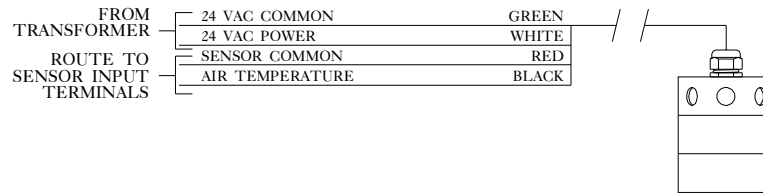

VENTMATE PLUS
SENSORS - PAGE 1 OF 2

Project VENTMATE TEMPERATURE SENSORS

Order ID	N/A
Distributor	N/A
Date	8/30/04
Drawn by	SB

SENSOR COMMON

BLACK

PHOTOCELL

RED

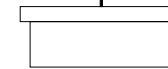

PHOTOCELL

Project	VENTMATE PLUS PHOTOCELL SENSOR	
	Order ID	N/A
Drawn by	GH	
	Date	01/24/02
Distributor	N/A	

VERRIDE INPUT
SENSOR COMMON

VERRIDE INPUT

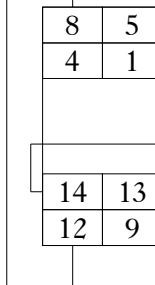

RELAY IS A DPDT
 14, 13 ... 24 VAC COIL
 12, 9 COMMON TERMINALS
 8, 5 NORMALLY OPEN TERMINALS
 4, 1 NORMALLY CLOSED TERMINALS

24 VAC FROM OVERRIDE DEVICE
 SUCH AS WEATHERMASTER OR
 WEATHERMATE.

VENTMATE PLUS SENSOR - PAGE 2 OF 2

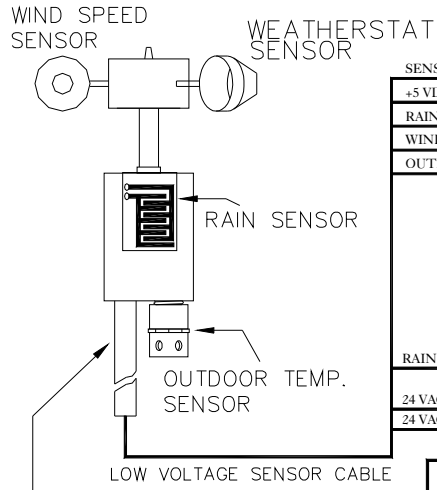

1/2" RIGID GALVANIZED MOUNTING CONDUIT

24 VAC TRANSFORMER
40 VA MINIMUM RATING

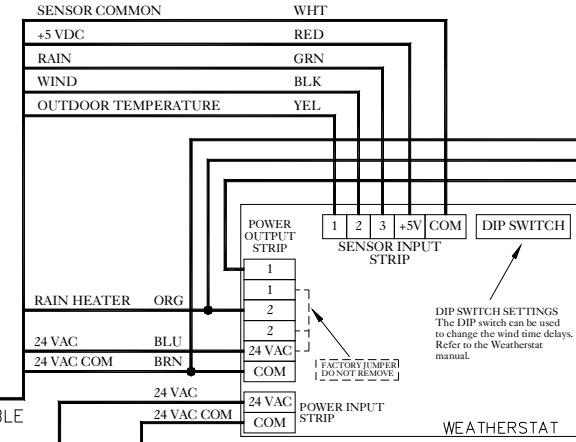

OUTPUT NOTE:
THE OUTPUTS OF THE WEATHERSTAT MAY CONNECT DIRECTLY TO THE OVERRIDE INPUTS OF A CONTROL SYSTEM CAPABLE OF ACCEPTING A 24 VAC SIGNAL. IF OTHER SWITCHING IS DESIRED, THE OUTPUTS MAY BE CONNECTED TO THE COILS OF CONTROL RELAYS TO INTERRUPT THE AUTOMATIC OPERATION OF VENTS, RETRACTABLE ROOFS, ETC.

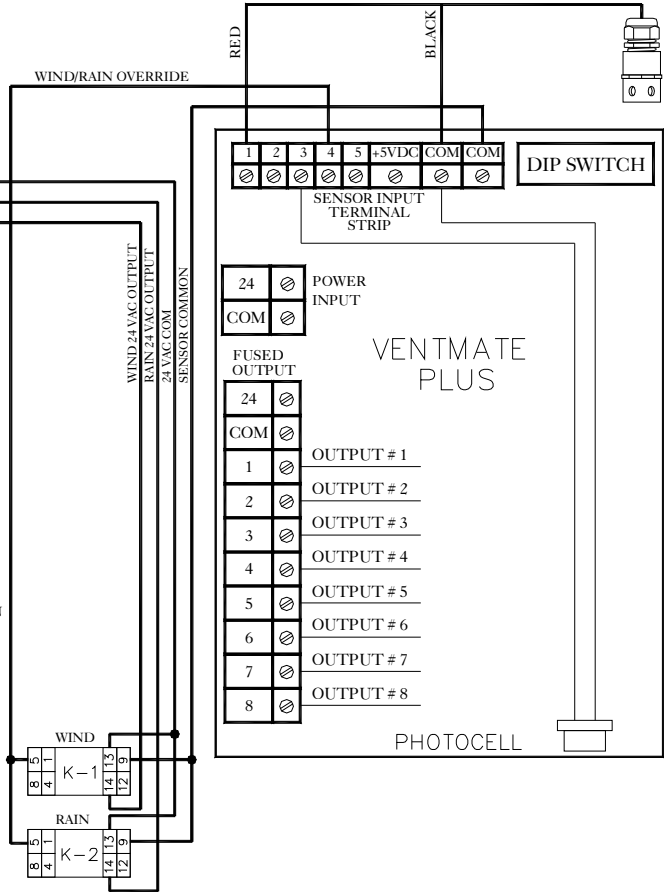

LOCATE SENSOR IN THE CENTER OF THE CONTROLLED AREA, AT BENCH OR CROP LEVEL, AWAY FROM DIRECT CONTACT WITH GREENHOUSE METAL POSTS AND MEMBERS.

VENTMATE PLUS DIRECT OVERRIDE CONNECTIONS

Project	VENTMATE PLUS DIRECT OVERRIDE CONNECTIONS	
	Order ID	N/A
Drawn by	Distributor	
	GH	N/A
Date	01/29/02	

LIMITED WARRANTY

Micro Grow Greenhouse Systems, Inc. warrants that all of the products Micro Grow Greenhouse Systems, Inc. manufactures are free from defects at the time of shipment by Micro Grow Greenhouse Systems, Inc. This warranty covers defects in workmanship and materials. No warranty is extended on any parts, materials, or components manufactured by others and purchased by Micro Grow Greenhouse Systems, Inc., and any warranty on these materials is limited to the warranty supplied by the original manufacturer or supplier of said products only. This warranty excludes any and all damages cause by installation by unqualified individuals, damage by misuse or neglect, shipment damage, alterations to original manufacturing, and improper installation or use for any reason than intended by manufacturer. This warranty may not be altered in any manner except with the written authorization of one the officers or owners of Micro Grow Greenhouse Systems, Inc. The only and sole liability of Micro Grow Greenhouse Systems, Inc. under this warranty is limited to repairing, replacing or the issuance of credit for any products returned to Micro Grow Greenhouse Systems, Inc., during the warranty period of twelve (12) months from date of shipment. This warranty is specifically conditioned upon Micro Grow Greenhouse Systems, Inc. being notified in writing promptly upon discovery of any product defects by the buyer or end user. The product must then be returned prepaid to Micro Grow Greenhouse Systems, Inc. within the twelve month warranty period for inspection by Micro Grow Greenhouse Systems, Inc. Upon inspection of said product, Micro Grow Greenhouse Systems, Inc. will notify buyer or end user of its findings. At Micro Grow Greenhouse Systems, Inc. sole discretion, the product will be replaced, repaired or a credit will be issued for the original sale price of the product, provided that damage has not occurred due to misuse, neglect, improper use or installation as outlined above, shipping damages or accident.

MICRO GROW GREENHOUSE SYSTEMS, INC. SHALL NOT BE LIABLE FOR ANY DAMAGES BEYOND THE ACTUAL ORIGINAL COST OF THEIR PRODUCT EITHER DIRECTLY OR INDIRECTLY ARISING FROM DEFECTIVE PRODUCTS OR WORKMANSHIP.